

SILICON UPDATE

Tom Cantrell

I'm a Traveling Man

What season is it, anyway? I would say summer, but for Tom and many others it's conference and trade show season. So, pack your suitcase, kiss the spouse goodbye, and get ready for the ride because Tom is taking us on the road with him. Our first stop—FPGAs.



It's that time again. Summer is in full swing, and the designer's fancy turns to a calendar of conferences, trade shows, and other soirees that mark the season.

It can be a rough life on the show circuit. Traffic and parking hassles, endless meetings, and pressrooms with no coffee (what are they thinking?). Nevertheless, it's still a rejuvenating ritual to make the rounds and discover the latest crop of goodies. Fortunately, when it comes to the March of Silicon, every year is a wonder year.

FUN WITH FPGAs

It's no secret that FPGAs are a hot item. Far beyond mere rocket science and one-off or prototyping applications, don't be surprised to see FPGAs encroaching on both ASIC (i.e., gate arrays) and standard merchant market IC sockets (such as MCUs, DSPs, and peripheral controllers).

The folks at Xilinx have been pushing their new Virtex parts with a pas-

sion, somewhat successfully judging by the emergence of third-party evaluation kits and development tools.

On the top of my two-foot stack of press kits I find Wildcard from Annapolis Micro Systems (see Photo 1). If this little puppy doesn't get your engineering juices flowing, you're either dead or should consider changing careers.

Wildcard crams a high horsepower Xilinx Virtex XCV300 (300k+ gates, 300+ pins, and 64 Kb of RAM) into a single height Type II PC Card slot. Just the thing for road warriors who do their FPGA designing on the run.

Thanks to a 32-bit 33-MHz CardBus (i.e., PCI) and 512-KB on-card RAM (dual 32-bit wide RAM arrays), the Wildcard can also work as a special-purpose accelerator add-on for laptops and portables. Applications that come to mind include signal and image processing, encryption/decryption, data acquisition, waveform generation, and so on.

Another XCV300-based design (see Figure 1) comes from a seemingly unlikely source, Avnet Inc. After all, distributors are useful for kitting orders, programming OTPs, and such, but since when is Avnet in the business of selling development tools under its own label?



Photo 1—The Wildcard from Annapolis Micro Systems puts a big chip (Xilinx XCV300) in a small package.

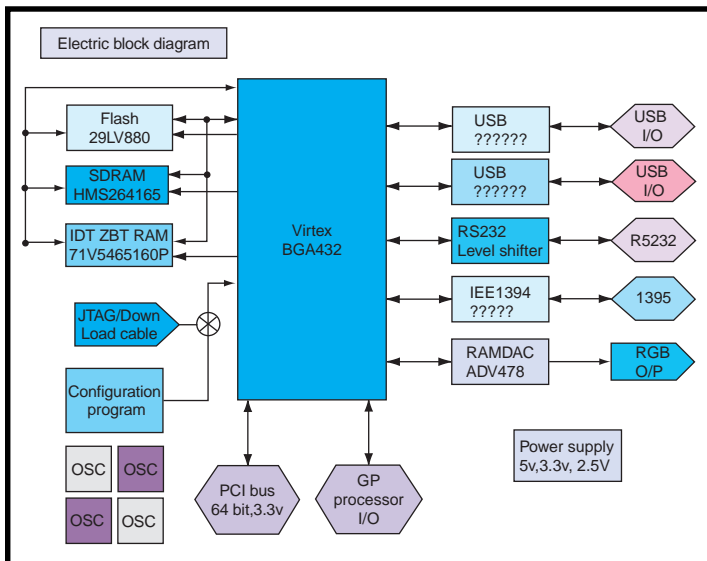

Figure 1—When it comes to FPGA development tools, who you gonna call? Avnet offers their own PC plug-in Virtex development system.

In fact, FPGAs and distributors are a match made in heaven. By contrast, despite a number of attempts, distributors have not managed to grab a piece of the ASIC action. I suspect they'll find FPGAs a much better fit with the mass market they serve. And, what better way to get in line for a chip PO down the road than by supplying tools up front?

Until now, XESS Inc. has been best known for entry-level kits, combining inexpensive \$100–\$200 evaluation modules and a book (*The Practical Xilinx Designer Lab Book*) that is chock full of examples and exercises written by the company founder, Dave Vanden Bout.

Now going upscale, in addition to a Virtex FPGA, XESS's new XSV board

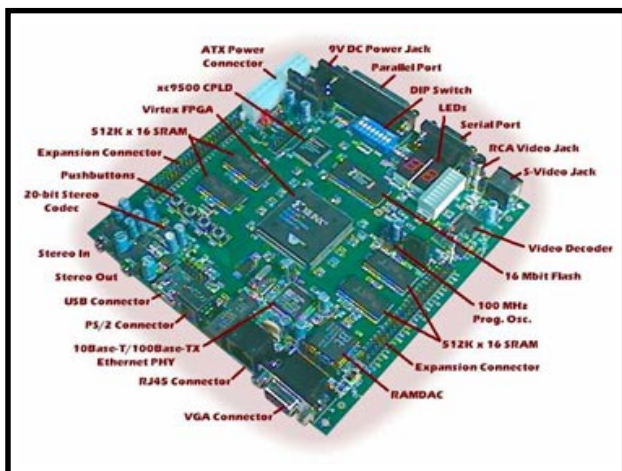

Photo 2—Roll your own computer with the XSV board from XESS.

(see Photo 2) packs a lot of distinctly PC-like punch, including video, audio, Ethernet, USB, and so on. Versions are available with 50k, 100k, and 300k gate FPGAs (i.e., XCV50, 100, and 300 chips) for \$699, \$749, and \$899, respectively.

Remember

the good-old days before PCs and Macs when hard-core engineers built their own computers from scratch? The XESS board seems like a perfect way to relive those heady times, and you don't even have to know how to solder.

KEY TO THE I-WAY

Should everything with an electron moving through it be on the I-way? That's the embedded Internet question. Because the answer is maybe, there's only one way to find out. You have to get your gadget online and see if customers salute.

There's a small problem, though. Namely, that adding an Internet connection is expensive,

especially considering the price tag for a 32-bit CPU, full-blown RTOS, and industrial strength TCP/IP stack.

The best of this breed are minimalist embedded PCs and integrated (CPU, RTOS, and network I/O) 32-bit chips from the likes of HP and NetSilicon. However, you're looking at \$50 to \$100 minimum

before all is said and done with these solutions.

Cutting the price tag is where things get interesting. There are a variety of options with various cost and function tradeoffs.

No doubt the emWare approach offers the lowest possible node cost, essentially just a few hundred lines of code tacked onto your existing embedded design. But, it requires a gateway to do the protocol heavy lifting. Thus, the approach is great in situations where a lot of nodes can share a gateway, or the gateway is already there.

Standalone sub 32-bit solutions are at the bleeding edge. Here you can find custom protocol handlers that cut the fat, running on 8-bit CPUs, notably the Microchip PIC and Scenix SX. The challenge with this approach is in understanding the compatibility and functional implications for your application related to the unavoidable

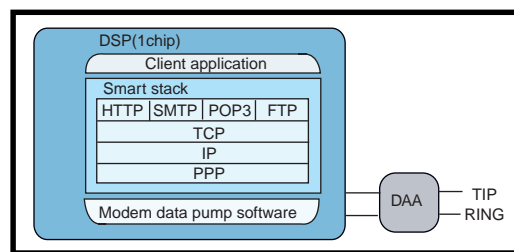

Figure 2—SmartStack from eDevice cuts the embedded Internet BOM to the bone.

compromises involved in downsizing the protocol code.

Another intriguing option is the iReady protocol ASIC technology found under the hood of chips such as the Seiko 4600A. Consider it a network UART, which offloads your embedded design of most of the networking drudge.

There's also a flurry of activity porting fully functional TCP/IP stacks to low-cost controllers and DSPs.

One new player is eDevice, whose SmartStack software (see Figure 2) requires only a DSP, flash memory, and a DAA (data access arrangement). The SmartStack not only handles the protocols but also the modem data pumping up to 56 Kbps (V90).

As a division of Z-World, Rabbit Semiconductor is taking advantage of that company's well-respected Dynamic C development environment



Photo 3—Rabbit Semiconductor brings TCP/IP (not to mention ICMP, HTTP, SMTP, and FTP) to the masses.

by offering what looks to be a full-featured TCP/IP stack at a bargain price. The TCP/IP development kit (see Photo 3) includes a Rabbit 2000 board with Ethernet connection, the complete Dynamic C development environment, and full TCP/IP source code, all for just \$199.

I am interested in how low the embedded I-way can go. It's simply Econ 101. The less it costs to get online, the more apps produced. If you're in town, drop by the Embedded Internet Conference (www.embeddedinternet.com) this September. I'm chairing a couple of sessions devoted to low-cost web hardware and can't wait to see the latest and greatest.

IT'S A SMALL WORLD AFTER ALL?

A trip to Sensors Expo is always fun because the show is in Anaheim, and the Disney influence lends a fantasyland feeling to the affair.

The latest developments on the sensor front are indeed fantastic, especially the excitement around micromachine technology and MEMS (micro electro-mechanical structures). They are tiny machines built in silicon, meaning they can be smart and connected. It also means that, like regular chips, they'll cost less tomorrow.

You've probably heard the more tabloid-like predictions for micromachines, such as tiny robots that can go on a fantastic voyage through your body, roto-rootering the

excess fries and pizza along the way.

People who are involved in the biz know that the micromachine concept isn't a fantasy. In fact, micromachined devices (such as accelerometers and pressure sensors) already enjoy widespread commercial success.

But, that's just the start. There's no shortage of interesting things to sense or folks who propose to sense them with some kind of micromachine. A micromachine sensor can mimic an earlier electro-mechanical version while taking advantage of the cost saving, size reduction, and the improved reliability and accuracy of silicon.

Consider the story at Hygrometrix Inc. As their name implies, they're in the business of making humidity sensors. For more than 30 years, Hygrometrix has offered what might best be described as an electro-organic humidity sensor comprised of strain gages connected to cellulose crystal-lite structures, which are harvested from the humidity sensitive seed-throwing mechanism of a geranium.

It sounds whimsical, but works well. Accuracy, linearity, and repeat-

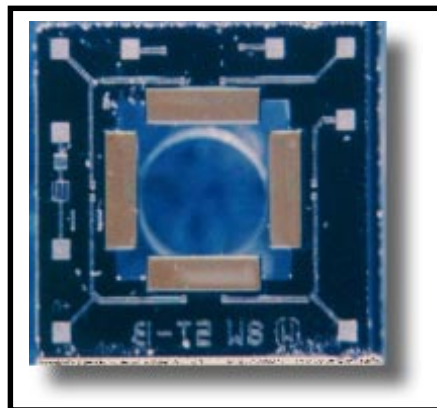

Photo 4—Prove to yourself that it isn't the heat, it's the humidity with the micromachined Hygrotron from Hygrometrix.

ability are all good, within a couple of percent or so, and the design tolerates environmental extremes. However, it is slow to respond (5 min. to react to a large step change) and expensive to produce.

Now, Hygrometrix has refreshed the design with MEMS technology. A polymer bonded to silicon reacts to water activity like the geranium, exerting force on a four-beam micromachined strain gage. The result is that the Hygrotron (see Photo 4) does everything the older flower power design did, only faster (5-s step change response) and at half the price!

Although the focus at the Sensors Expo is naturally biased toward sensing, MEMS technology can also be put to work. One of the first and perhaps

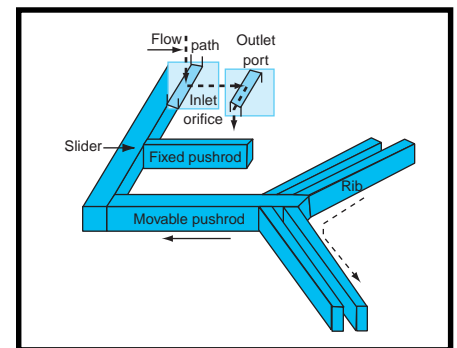

Figure 3—Lucas Novasensor shows off the micromachined fluid valve, which is basically a silicon squirt gun.

best known example is the mirror arrays made by TI that are used in the latest high-end projection systems.

So besides sensing, expect to see plenty of MEMS actuator applications, such as the micromachined fluid valve from Lucas Novasensor (see Figure 3).

Computers are pretty good at seeing, feeling, and hearing, but smell is one human sense they haven't acquired yet. Oops! I spoke too soon judging by the zNose from Electronic Sensor Technology.

I must confess, I'm not sure how the lashup of a six-port two-position sampling valve, a temperature programmed gas chromatography column, an integrated thermo-electric

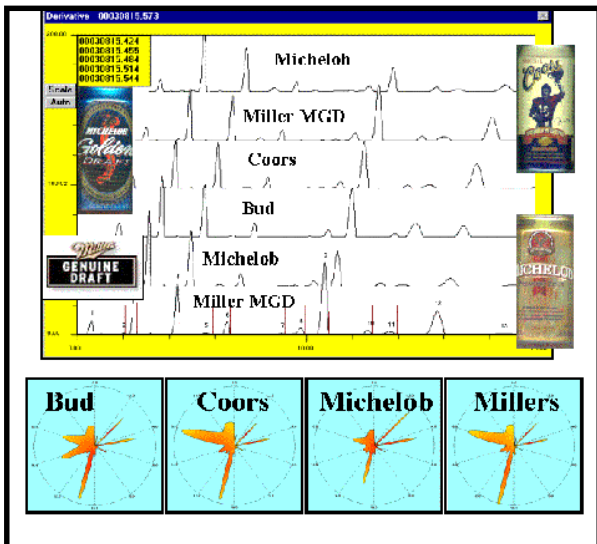

Photo 5—Less Filling? Tastes Great?
Only the zNose knows.

heating element, and a SAW (Surface Acoustic Wave) detector works. But, according to the company, it's the only electronic nose to be validated by the EPA. Judging by the screen shot (see Photo 5), this vaporware is real!

I can only begin to contemplate the interesting applications posed by such technology. How about a home-brew halitosis detector, a body odor buster, or maybe even a dirty-diaper alarm? Don't you just love this business?

Well, that's it for this report from the road. But don't worry, the show season is just getting into full swing. It won't be long before I'm back pounding the floor, picking up press kits, praying I can find a cup of coffee, and loving every minute of it. ☺

Tom Cantrell has been working on chip, board, and system design and marketing in Silicon Valley for more than ten years. You may reach him by e-mail at tom.cantrell@circuitcellar.com, by telephone at (510) 657-0264, or by fax at (510) 657-5441.

SOURCES

MEMS humidity sensor
Hygrometrix Inc.
(619) 659-9292
Fax: (619) 445-7471
www.hygrometrix.com

zNose electronic vapor sensor
Electronic Sensor Technology
(805) 480-1994
Fax: (805) 480-1984
www.estcal.com

Silicon valve
TRW Novasensor
(800) 962-7364
(510) 661-6000
Fax: (510) 770-0645
www.novasensor.com

XSV board
Xess Corp.
(919) 387-0076
Fax: (919) 387-1302
www.xess.com

Virtex parts
Xilinx
(408) 559-7778
Fax: (408) 559-7114
www.xilinx.com

Virtex Development System
Avnet Design Services
(408) 643-2000
www.avnetmarshall.com

Wildcard
Annapolis Micro Systems, Inc.
(410) 841-2514
Fax: (410) 841-2518
www.annapmicro.com

Rabbit 2000 TCP/IP Development Kit
Avnet Design Services
(530) 757-8400
Fax: (530) 757-8402
www.rabbitsemiconductor.com

SmartStack software
EDevices Inc.
(212) 856-0000
Fax: (212) 856-9339
www.edevice.com

Circuit Cellar, the Magazine for Computer Applications. Reprinted by permission. For subscription information, call (860) 875-2199, subscribe@circuitcellar.com or www.circuitcellar.com/subscribe.htm.